

35G SPECIFICATIONS

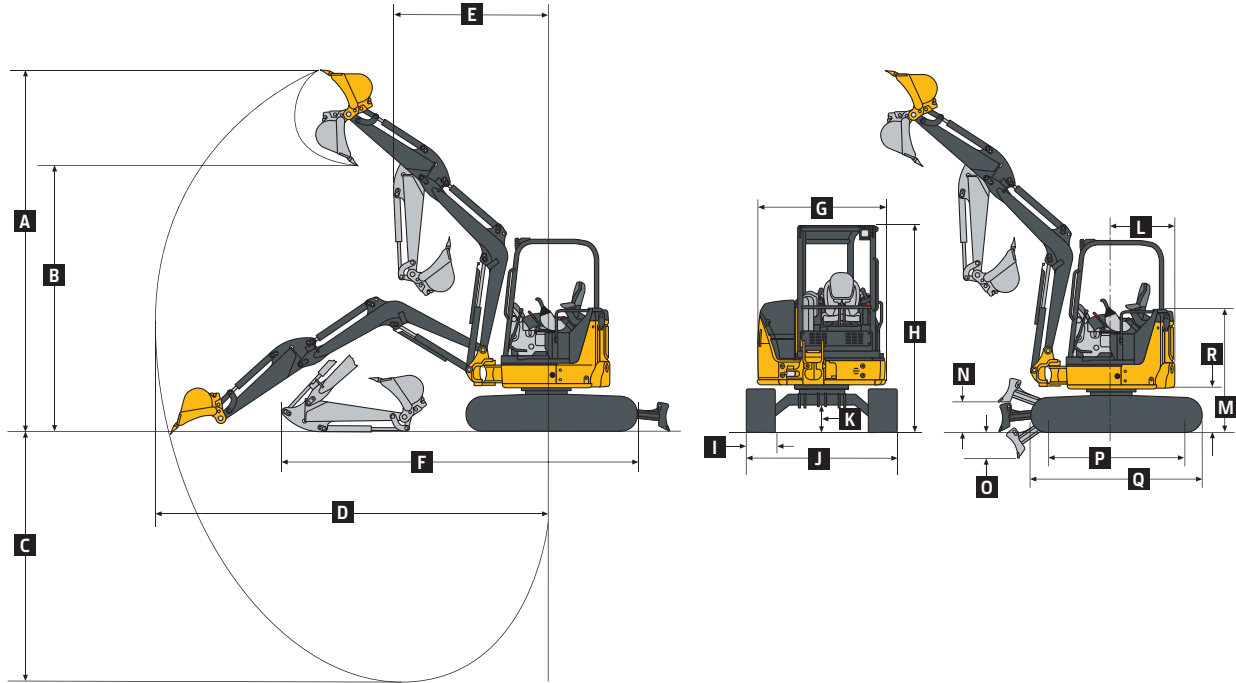

While general information, pictures, and descriptions are provided, some illustrations and text may include product options and accessories NOT AVAILABLE in all regions, and in some countries products and accessories may require modifications or additions to ensure compliance with the local regulations of those countries.

Operating Dimensions	35G			
	1315-mm (4 ft. 4 in.) Standard Arm and Canopy	1315-mm (4 ft. 4 in.) Standard Arm and Cab	1715-mm (5 ft. 8 in.) Long Arm and Canopy	1715-mm (5 ft. 8 in.) Long Arm and Cab
A Maximum Cutting Height	4.87 m (16 ft. 0 in.)	4.70 m (15 ft. 5 in.)	4.95 m (16 ft. 3 in.)	4.74 m (15 ft. 7 in.)
B Maximum Dumping Height	3.46 m (11 ft. 4 in.)	3.31 m (10 ft. 10 in.)	3.57 m (11 ft. 9 in.)	3.39 m (11 ft. 1 in.)
C Maximum Digging Depth	3.06 m (10 ft. 0 in.)	3.06 m (10 ft. 0 in.)	3.46 m (11 ft. 4 in.)	3.46 m (11 ft. 4 in.)
D Maximum Digging Reach	5.21 m (17 ft. 1 in.)	5.21 m (17 ft. 1 in.)	5.52 m (18 ft. 1 in.)	5.52 m (18 ft. 1 in.)
E Minimum Front Swing Radius	2.08 m (6 ft. 10 in.)	2.24 m (7 ft. 4 in.)	2.19 m (7 ft. 2 in.)	2.30 m (7 ft. 7 in.)
F Transport Length	4.64 m (15 ft. 3 in.)	4.64 m (15 ft. 3 in.)	4.75 m (15 ft. 7 in.)	4.75 m (15 ft. 7 in.)
Digging Force (ISO)				
Arm	19.0 kN (4,277 lb.)	19.0 kN (4,277 lb.)	16.9 kN (3,792 lb.)	16.9 kN (3,792 lb.)
Bucket	27.1 kN (6,085 lb.)	27.1 kN (6,085 lb.)	27.1 kN (6,085 lb.)	27.1 kN (6,085 lb.)



Machine Dimensions			
G Upperstructure Width	1.55 m (5 ft. 1 in.)	M Engine Cover Height	1.53 m (5 ft. 0 in.)
H Overall Height		N Maximum Blade Lift Above Ground	360 mm (14.2 in.)
Canopy	2.48 m (8 ft. 2 in.)	O Maximum Blade Drop Below Ground	400 mm (15.7 in.)
Cab	2.48 m (8 ft. 2 in.)	P Blade	
I Track Width	300 mm (12 in.)	Width	1.74 m (5 ft. 9 in.)
J Undercarriage Width	1.74 m (5 ft. 9 in.)	Height	373 mm (14.7 in.)
K Ground Clearance	280 mm (11 in.)	Q Sprocket Center to Idler Center	1.66 m (5 ft. 5 in.)
L Tail Swing Radius		R Undercarriage Length	2.11 m (6 ft. 11 in.)
With Standard Arm	870 mm (34 in.)	R Counterweight Clearance	550 mm (22 in.)
With Long Arm and Extra Counterweight	980 mm (39 in.)		

Lift Capacities								
Ground Level at 3.05-m (10 ft.) Radius	Canopy and Standard Counterweight		Cab and Standard Counterweight		Canopy and Extra Counterweight		Cab and Extra Counterweight	
	Over Front	Over Side	Over Front	Over Side	Over Front	Over Side	Over Front	Over Side
1315-mm (4 ft. 4 in.) Standard Arm	1568 kg (3,453 lb.)	641 kg (1,412 lb.)	1568 kg (3,453 lb.)	684 kg (1,506 lb.)	1568 kg (3,453 lb.)	765 kg (1,686 lb.)	1568 kg (3,453 lb.)	808 kg (1,780 lb.)
1715-mm (5 ft. 8 in.) Long Arm	1501 kg (3,307 lb.)	630 kg (1,388 lb.)	1501 kg (3,307 lb.)	672 kg (1,481 lb.)	1501 kg (3,307 lb.)	755 kg (1,662 lb.)	1501 kg (3,307 lb.)	797 kg (1,756 lb.)